

Instruction



Contents

Instruction	3
Before you set out	4
Hitching the COMBI-CAMP	5
Opening the trailer and erecting the tent	6
Final adjustment	7
Integrated sun canopy / awning	8
Integrated sun canopy / awning	9
Sun canopy as kitchen canopy	10
Accessories to the trailer tent	11
Kitchen	12-13
Maintenance	14-15
Technical data	16-17

CONGRATULATIONS

ON YOUR NEW COMBI-CAMP



We are delighted that you have chosen COMBI-CAMP and we wish you many happy holidays in the years to come.

This booklet has been created to help you get the optimum from your COMBI-CAMP trailer tent, and we advise you to read it carefully.

Get to know your COMBI-CAMP at home - erect the trailer tent a few times, so that you have good knowledge of what to do before you embark on the first trip.

BEFORE YOU SET OUT

Check points:

- Close and securely lock all locks on trailer and kitchen
- Check the proper function of all road lights before you start your trip
- It is important to tighten wheel nuts after driving the first 200 km.
- If your COMBI-CAMP is equipped with brakes, they must be adjusted after driving the first 200 km.
- Check that your hitch is correctly attached to the car.
- Check that the jockey wheel is tightened and in its upper position.
- Check your trailer speed limits especially in foreign countries and fit your national identification plate.



Packing the COMBI-CAMP

- Inside the closed trailer there is room for approx. 34 cubic feet (1 cubic metre) worth of luggage space. Furthermore, there is luggage space on the roof rack. Please note that packing must be carried out in a way that ensures the balance of the trailer.
- Heavy items should be placed on the axle line even if only the roof rack is used. The weight at the hitch should be between 44-110 pounds (20 to 70 kg).

- Do not place luggage too close to the outer walls of the trailer -

there must be 8 inches of space left to accommodate the tent and frames. This will ensure proper closure of the trailer lid.

- The approved gross weight of all COMBI-CAMP trailers is 750 kg.

HITCHING THE COMBI-CAMP

- The handle is, in the upper position i.e. open, then the hitch is lowered by using the jockey wheel on to the vehicles tow bar.
- When the hitch is in the correct position, the green indicator on the front of the hitch will be visible and the handle will automatically move to the normal position.
- Remember to attach the safety cable, which activates the brakes in case the trailer becomes detached from the tow bar.

Light

- Always remember the trailer's, electrical plug must be inserted to the vehicle. See diagram page 18.

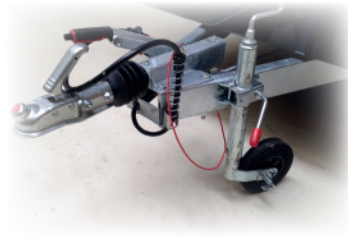

OPENING THE TRAILER AND ERECTING THE TENT

- Opening the trailer tent should be carried out on a fairly level site.
- Remember it is not recommendable to place the trailer under trees. Objects can fall down and eventually damage or discolour the tent canvas.
- When the COMBI-CAMP is unhitched and placed on the desired spot, using the front support leg or jockey wheel if fitted to level the trailer tent.
- Wind down the rear jack legs until trailer is level, it is recommended to have a jack plate to avoid the leg going into the ground, then unhook the roof rack.
- Lift the roof rack over the trailer all the way.



- Now open the top of the trailer, pull it towards and past the position of the roof rack and further until it reaches the ground.



Never use the roof rack as a lever. Walk into the tent and push up the two connect poles on the centre trailer frame until the tent is fully erected and tighten the handscrew.



- The tent canvas is now erected. Adjust the internal frame adjusters as shown. Adjust the jockey wheel in order to level the tent floor so that it is supported by the roof rack which is now situated below the floor. If required the two rear jack legs can also be adjusted.



FINAL ADJUSTMENT

- Pull the rain protection skirt out over the trailer and adjust the nylon skirt over the floor edge.
- All windows are complete with ventilation panels fitted with mosquito nets. Should you wish ventilation, roll the canvas part to side and tie. Should it rain, the panel can be opened just a little with use of a guy rope into the "D" ring located at the bottom of the panel.
- The zippers on both ends of the hinge should always be closed by approx 15 cm.
- Finally the outside vent can be opened. Zip up and place the fibreglass section into the sleeve and bend the section and insert into the pocket in the other side.



Extra checkpoint when setting up the main tent

- The bands with buckles on all corners of the main tent should be tight to avoid leaking on these spots.

Has the buckle come loose, make sure you pull the band until the roof is flat and then close the buckle again.



INTEGRATED SUN CANOPY/AWNING

Erection of integrated, sun canopy/awning

The frame system is shown in fig. 6

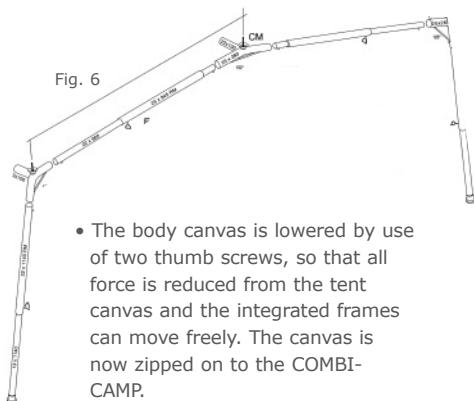

- The body canvas is lowered by use of two thumb screws, so that all force is reduced from the tent canvas and the integrated frames can move freely. The canvas is now zipped on to the COMBI-CAMP.

- The sun canopy is put on top of the integrated frames, whilst they are pulled out. Both the frames 25 mm and 22 mm are pulled out, such as the little pressure spring is engaged into the 25 mm frame and this is pulled out 3/4 way.
- Hereafter the front section of the frame is attached (fig. 6). Now the frame is adjusted so that the canvas is nice and tight.

- The height is adjusted on the two legs. Adjust the integrated frames and lock the adjuster.
- The side can now be pegged or rolled back to the trailer.



IMPORTANT: make sure the elastic flap is covering the zipper.

INTEGRATED SUN CANOPY/AWNING

- The small elastic can easily be attached to the awning "D" rings.
- The draught skirt is fitted below the kitchen.



- To adjust the backrest/foot of the lits jumeaux in the Country, you can lift and fix it in stages. To return to flat position, first move it fully towards you to unlock it.



- When closing the trailer down, to save time you may leave the sun canopy attached and stored on top of the trailer roof.

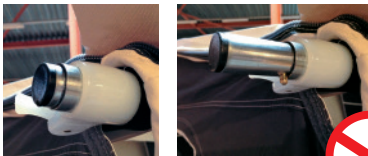

Important - when closing the integrated frames they must be pushed all the way back.



SUN CANOPY AS KITCHEN CANOPY

Sun canopy as kitchen canopy

- If you are having a one night stop, for ease you can move the integrated frames halfway out and fold the rest of the roof below the canopy roof.
- When the sun canopy is still on top of the trailer, pull out the 22 mm frame approx. 10 cm (4") until the pressure spring becomes visible.

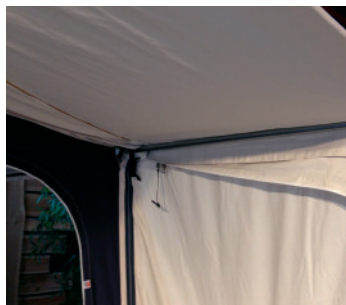

- Hereafter pull out the 25mm frame approx. 1m (3'4").
- The sun canopy is pulled forward and the frame is inserted into the small grey PVC pockets.

- Please note that the canopy must be on top of all frames.
- The frame's adjusters are tightened and the loose hanging sun canopy is tightened to the trailer body canvas by using the ribbons.
- The sides can either be pegged or attached to the body canvas.

ACCESSORIES TO THE TRAILER TENT

Fitting the annex:

- The detachable side of the trailer's body canvas is zipped out.
- The annex cabin is zipped in.
- The poles with accompanying two round corners are put into the sleeve inside the annex.
- The support poles with hook end are put into the two holes in the trailer's steel section at the floor.
- The PVC floor of the annex is then stretched and pegged all the way round, do not tighten too much.

- Finally place the fibre glass pole inside the ventilation flap, where after the inner tent is fitted.

The door canopy is fitted as follows:

- The door canopy is zipped together and the poles are fitted with guy ropes.

Extra sun canopy is fitted as shown:

- The sun canopy has 3 brass eyelets in each end. The one fits the awning frames spigots and is then attached to the guy rope on each side. The 3 legs are fitted and pegged with the guy rope.



KITCHEN



Fridge

- Before using the fridge you should clean the inside and outside with lukewarm water containing a mild detergent. From time to time, the rubber-seal of the lid should be rubbed with a little talcum powder.
- The fridge can be used with 12v, 220/240v or gas (Propane or Butane only). The regulator supplied is to fit the blue Camping Gaz bottle.

Electric operation

- If you wish the unit to operate from 12v, it is advisable to pre-cool with mains 12 hours before going on tour. Mains are connected by using the two pin plug fitted on the back of the fridge unit.

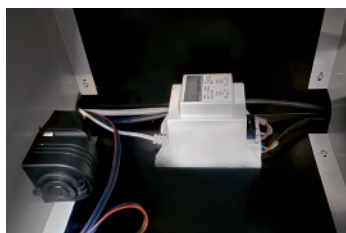

Liquid gas operation

- Regulator B is pressed down and kept in this position for 10 seconds. This is clearing the pipes from any oxygen and gas, which may reach the burner unit. This, on a new unit can take a few attempts.
- The burner is ignited by pressing button "E" down a few times.

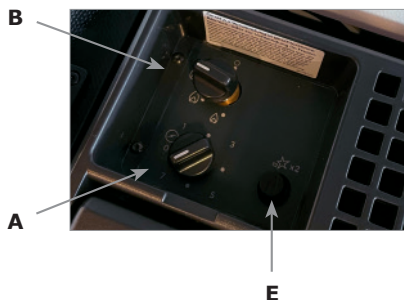

- When the desired temperature is reached regulator "B" is turned backwards towards position "MIN".
- Remember to cut the gas supply when the refrigerator is no longer running on gas.

KITCHEN

- Do not damage the wiring of the lights when placing items in the kitchen.



Gasburners

The kitchen has three burners that function in the following manner:

- Open the gas supply tap.
- The control switch is turned to the big flame and pressed in.
- Whilst depressing the control switch the burner is ignited by using a lighter. To activate the automatic ignition safely, keep pressing on the control switch for approximately 5-10 seconds. Should the flame go out, please repeat this function.
- Release the control switch and turn it to the desired position.

PLEASE NOTE.

Do not cover the ventilation on the front panel.

Gas taps

- One tap is for the fridge and the other for the gas burners on the cooker top. The open position is in the vertical. The taps can be used separately.



Fitting the regulator to gas bottle

- Screw the regulator on to the bottle until tight. The regulator is open when in position "O" and closed in position "F".

The water tap

- The water tap works on 12 volt, provided by a converter placed under the small drawers. Power is provided by the connection to the car, or when the trailer is connected to power supply.
- Do not try to use the tap when the pump is not fully covered in water. While driving please take out the pump and use the closed cap of the water container.

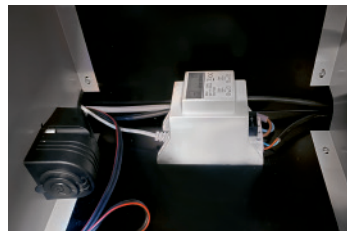

MAINTENANCE

Be good to your COMBI-CAMP, this will serve both you and your COMBI-CAMP best. A reasonable maintenance will ensure you a reliable trailer tent for many years to come.



The tent

- The COMBI-CAMP can be very easily opened and closed even in rainy weather. If you had to pack in misty weather it is advisable to open the trailer as soon as possible to give it fresh air and to dry the tent canvas and the mattresses, otherwise you may face mould and consequently rot. However, should signs of such occur the only treatment is to dry the attacked spot thoroughly and then brush it down, clean and re-impregnate the canvas.
- It is therefore important that your COMBI-CAMP is not left wet for longer periods than 24 hours when closed.
- Use of chemical cleaners is not advisable.
- Please note that the mattress covers can be cleaned at maximum 30 degrees, as it otherwise loses its form, alternatively, it should be dry-cleaned.
- Normal dirt can be washed with water adding a little vinegar and a soft brush. Most often an effective cleaning can be done with a vacuum cleaner.
- Separate all poles, make sure they are dry, and put them in the provided bag.
- **The telescopic poles of the awning should be taken out and stored dry, together with the other poles.**
- Leaking on seams can be solved by using a seam sealer. Since cotton is a natural material, colour difference in different parts of the tent may occur.

MAINTENANCE

Chassis / Roof rack

- Both the chassis and the roof rack have an effective rust proofing. The roof rack has been fitted with plastic protectors to minimise damage to the roof rack when opened against the ground.

Before the first trip:

- When you open your COMBI-CAMP for the first time, we strongly recommend that the tent canvas is sprayed with water. Even the finest impregnated cotton canvas is not 100% effective before the first rain shower.
- Whilst the tent is sprayed and later drying, it is important that the windows and doors remain closed as to secure a uniform shrinking of the tent canvas. All our cotton tent canvases are designed "shrink to fit". Do not fold down the tent before it is absolutely dry.
- The tent canvas is made from a natural cotton product. Should you experience a slight leak around the stitching of the canvas this can be cured by impregnating the seams with seal seam.

Storage

- See that the trailer and tent are completely dry before storage.
- You are well advised to remove mattresses as well as the inner tent and store in a totally dry spot during the winter.
- Take all poles apart, including the telescopic poles and store them dry in the bag provided.
- Make sure the hinges of the kitchen, support feet and jockey wheel are greased at all times.

TECHNICAL DATA

VALLEY

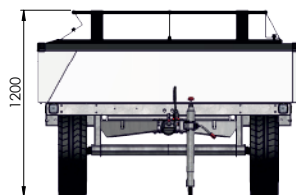
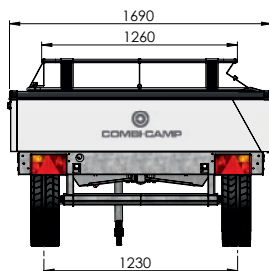
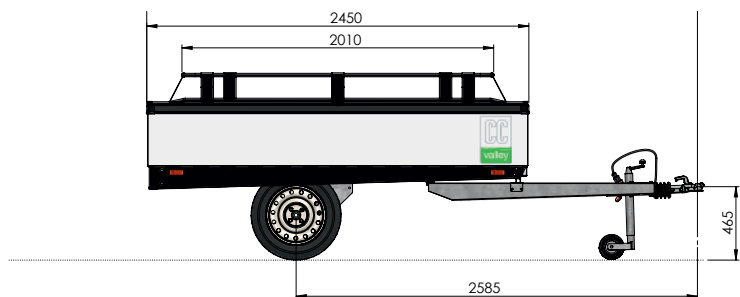

Net weight: 350 kg
Gross weight: 750 kg

TECHNICAL DATA

COUNTRY

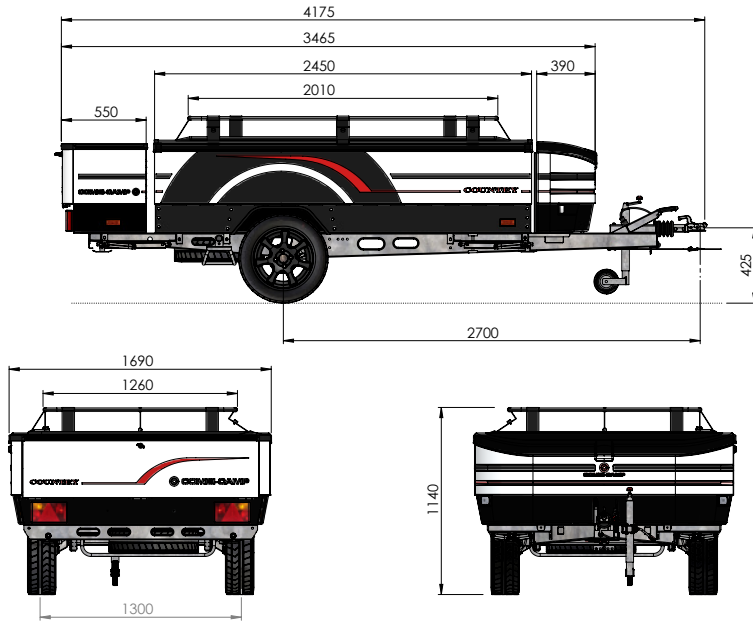

Net weight: 450 kg
Gross weight: 750 kg

Technical data



FITTING INSTRUCTION

13-POLE JAEGER

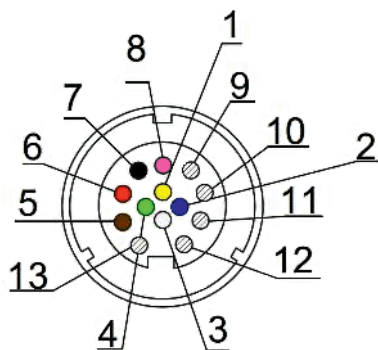

13-POLE MULTICON

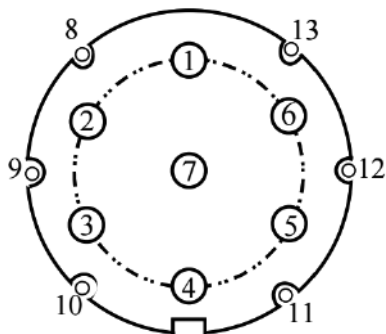

13-pole Multicon/Jaeger			
1	1/L	Left hand indicator	yellow
2	2/54G	Foglight	blue
3	3/31	Earth (contacts 1 t/m 8)	white
4	4/R	Right hand indicator	green
5	5/58R	Right hand lights and license plate	brown
6	6/54	Brake light	red
7	7/58L	Left hand lights	black
8	8	Reverse light	pink
9	9	Fridge + (2,5 mm)	not specified
10	10	Permanent flow/Water tap	not specified
11	11	Earth fridge (2,5 mm)	not specified
12	12	Not in use	not specified
13	13	Earth pole 9	not specified



COMBI-CAMP



www.combicamp.com